

INDUSTRIE ELEKTRIK

KOSTAL



Smart
connections.

Operating Manual
INVEOR MMI

Legal notice

KOSTAL Industrie Elektrik GmbH
An der Bellmerei 10
58513 Lüdenscheid
Germany
Phone: +49 2351 16-0
Fax +49 2351 16-2400
info-industrie@kostal.com

Exclusion of liability

All general names, trade names, product names or other designations used in this manual may be legally protected even if not labelled as such (e.g. as a trademark). KOSTAL assumes no liability for their free usage.

The illustrations and texts have been compiled with great care. However, the possibility of errors cannot be ruled out. The compilation is made without any guarantee.

General note on gender equality

KOSTAL is aware of how language impacts gender equality and always makes an effort to reflect this in documentation. Nevertheless, for the sake of readability, we are unable to use non-gender-specific terms throughout and use the masculine form instead.

© 2013 KOSTAL Industrie Elektrik GmbH

All rights reserved by KOSTAL, including those of reproduction by photocopy and storage in electronic media. Commercial use or distribution of the texts, displayed models, diagrams and photographs appearing in this product are not permitted. This manual may not be reproduced, stored, transmitted or translated in any form or by means of any media - in whole or in part - without prior written permission.

Contents

| | | |
|----------|---|-----------|
| 1 | Important information | 5 |
| 1.1 | Information about documentation | 5 |
| 1.1.1 | Other applicable documents | 5 |
| 1.1.2 | Storing the documentation | 5 |
| 1.2 | Symbols | 6 |
| 1.2.1 | Warnings | 6 |
| 1.2.2 | Signal words | 6 |
| 1.2.3 | Information | 6 |
| 1.2.4 | Text symbols | 6 |
| 1.3 | Qualified staff | 7 |
| 1.4 | CE marking | 7 |
| 1.5 | Safety instructions | 7 |
| 1.5.1 | General information | 8 |
| 1.5.2 | Disassembly & disposal | 8 |
| 1.6 | Proper use | 9 |
| 1.7 | Responsibility | 9 |
| 1.8 | Contacts for further information | 10 |
| 2 | Overview of INVEOR MMI | 11 |
| 2.1 | Scope of delivery | 11 |
| 2.2 | Model description | 11 |
| 2.3 | Description of INVEOR MMI | 12 |
| 2.3.1 | Functions | 12 |
| 3 | Operation | 13 |
| 3.1 | Function of buttons | 13 |
| 3.2 | Navigation and input | 14 |
| 3.3 | Menu | 15 |
| 3.4 | Motor detection | 16 |
| 3.5 | Specifying nominal value for the rotation speed | 20 |
| 3.6 | Parameter group menu (expert mode) | 21 |
| 4 | Technical data | 24 |
| 5 | Approvals, standards and guidelines | 24 |
| 5.1 | Standards and guidelines | 24 |
| 6 | List of key words | 25 |
| 7 | Notes | 26 |

1 Important information

This chapter contains important information on safe handling of the product and the operating manual.

1.1 Information about documentation

The following information explains how to navigate through the documentation.

Read this manual carefully in its entirety. It contains important information for operating the INVEOR MMI.

We assume no liability for any damage resulting from non-observance of this manual.

This manual is a part of the product and should be stored in a safe place. It applies exclusively to the INVEOR MMI from KOSTAL Industrie Elektrik GmbH.

Provide the operator of the system with this manual so it is available when needed.

1.1.1 Other applicable documents

This refers to all manuals that describe how to operate the drive control system and any other manuals for the equipment used. Download the 3D files (.stp) for INVEOR and adapter plates from www.kostal.com/industrie.

A description of parameters is available for download (www.kostal.com/industrie) for parametrising the drive control system. In the download, you will find all information required for correct parametrisation.

1.1.2 Storing the documentation

Store this manual and all other applicable documents safely so they are available when needed.

1.2 Symbols

1.2.1 Warnings



General warnings are labelled by a warning triangle with exclamation points.



A warning triangle with a lightning bolt indicates the risk of hazardous voltage.

1.2.2 Signal words

Signal words in warnings indicate the type and severity of the consequences if measures to avoid danger are not followed.

- DANGER means that life-threatening personal injury can occur.
- WARNING means that severe personal injuries can occur.
- CAUTION means that mild to moderate personal injuries can occur.
- NOTE means that material damage can occur.

1.2.3 Information



Important information without risks to persons or property is represented by the symbol on the left.

1.2.4 Text symbols

| | |
|---|------------------------------------|
| 1, 2, 3, etc. | Sequential steps of an instruction |
|  | Effect of an instruction |
| <input checked="" type="checkbox"/> | Final result of an instruction |

1.3 Qualified staff

In the context of this operating manual and the information relating to the product itself, qualified staff refers to electronics specialists who are familiar with the installation, assembly, start-up and operation of the drive control and the dangers involved, and whose specialist training and knowledge of relevant standards and regulations provide them with the necessary abilities.

1.4 CE marking

With the CE marking, we, as the manufacturer of the device, confirm that the basic requirements of the following guidelines are met:

- Directive on Electromagnetic Compatibility (Directive 2004/108/EC of the Council)

You can download the Declaration of Conformity at www.kostal.com/industrie.

1.5 Safety instructions

The following warnings, precautionary measures and comments are provided for your safety and serve to prevent damage to the drive control and the components connected to it. This chapter contains warnings and information that are generally applicable when handling drive controls. They are split into general information, transport & storage and dismantling & disposal.

Specific warnings and comments that apply to specific activities can be found at the start of the appropriate chapters and are repeated or added to at various critical points in these chapters.

Please read this information carefully as it is provided for your personal safety and will also prolong the life of the drive control and connected devices.

1.5.1 General information

 **DANGER!**

RISK OF DEATH DUE TO ROTATING PARTS!

The motor can rotate during the programming. Depending on the equipment, this can cause a dangerous situation for persons and the equipment.

Make sure that no one is located in hazardous zones and that the motor is disconnected.

 **DANGER!**

RISK OF DEATH DUE TO ELECTRIC SHOCK!

Hazardous currents are present on the motor and drive control. These can lead to injury or death.

When working on the device, de-energize the device and secure it from being switched on again.

NOTE

This operating manual must be kept near the device and available to all users.

1.5.2 Disassembly & disposal



Components with electronic parts may not be disposed of along with normal household waste. They have to be collected separately with waste electrical and electronic equipment in accordance with applicable legislation.

1.6 Proper use

The application and performance parameters of the INVEOR drive control from KOSTAL Industrie Elektrik GmbH are displayed and programmed with the INVEOR MMI. This device may only be used for the INVEOR drive control.

This device may only be used under the allowed environmental conditions. Incorrect use may cause damage to the device. The INVEOR MMI may only be used for its intended purpose. Any use that differs from or goes beyond the stated intended purpose is considered non-intended use. The manufacturer accepts no liability for any damage resulting from such non-intended use. Modifications to the INVEOR MMI are prohibited.

Any instance of misuse of the INVEOR MMI will result in the termination of the guarantee, warranty and general liability of the manufacturer.

The INVEOR MMI may not be operated in areas where there is a danger of explosion.

Repairs may only be performed by authorised repair bodies. Independent and unauthorised intervention may result in death, injury or property damage. The warranty provided by KOSTAL will be invalidated in such cases.

1.7 Responsibility

As a basic principle, electronic devices are not fail-safe. The operator and/or the contractor setting up the machine or system is responsible for ensuring that the drive switches to a safe state if the device fails.

The “Electrical equipment of machines” section in DIN EN 60204-1; VDE 0113-1:2007-06, “Safety of machinery” describes the safety requirements for electrical control units. These are provided for the safety of people and machines and must be observed in order to retain the functional capability of the machine or system.

An emergency stop feature does not have to result in the power supply to the drive being switched off. To avoid dangerous situations, it may be useful for individual drives to remain operational or for specific safety procedures to be initiated. The effectiveness of emergency stop measures is evaluated by means of a risk assessment for the machine or system and its electrical equipment, and is determined by selecting a circuit category according to DIN EN 13849 “Safety of machinery - Safety-related parts of control systems”.

1.8 Contacts for further information

Further information is available from:

Central service hotline

Phone: +49 2331 8040-4848

Monday - Friday: 7 am to 5 pm (local time)

Fax: +49 2331 8040-4811

E-mail: INVEOR-service@kostal.com

Website address

www.kostal.com/industrie

2 Overview of INVEOR MMI

This chapter contains information on the scope of delivery and the function description.

2.1 Scope of delivery

Compare your product with the scope of delivery provided below.

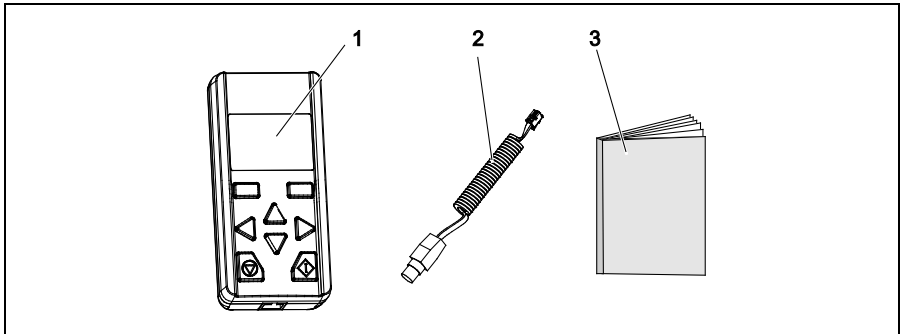

Fig. 1: Scope of delivery

- 1 INVEOR MMI manual control unit
- 2 Communication cable with RJ11 and M12 plug
- 3 Brief instruction

2.2 Model description



Fig. 2: Article designation of INVEOR MMI

- | | |
|--|---|
| 1 Accessories for INVEOR drive control series: ZUB | 4 Firmware version: S00 standard; S10 specific |
| 2 Drive control use: M - motor-integrated, BG - independent | 5 Version: 000 standard; 001 specific |
| 3 Article description: MMI | 6 Device generation: 1 - current version |

2.3 Description of INVEOR MMI

The INVEOR MMI is connected to the INVEOR M12 interface. The INVEOR MMI displays the parameters. The parameters are programmed with the function buttons.

Up to eight data records can be stored in an MMI. The data records can be copied to other INVEORs. The INVEOR MMI receives all signals for programming from the INVEOR drive control.



*The INVEOR MMI may only be operated with the INVEOR drive control!
Any other connection is not allowed.*

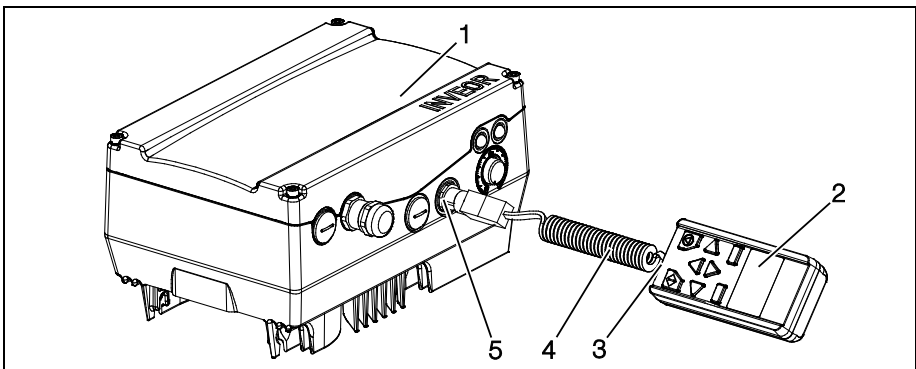

Fig. 3: INVEOR MMI with INVEOR drive control

- | | |
|----------------------------------|-----------------------|
| 1 INVEOR drive control | 4 Communication cable |
| 2 INVEOR MMI manual control unit | 5 M12 socket |
| 3 RJ11 socket | |

2.3.1 Functions

The following functions are possible with the INVEOR MMI:

- Parametrisation of device configuration
- Control (e.g. locking and releasing)
- Display of various process values
- Saving parameter sets (max. 8)
- Transferring parameter sets to different INVEORs

3 Operation

3.1 Function of buttons

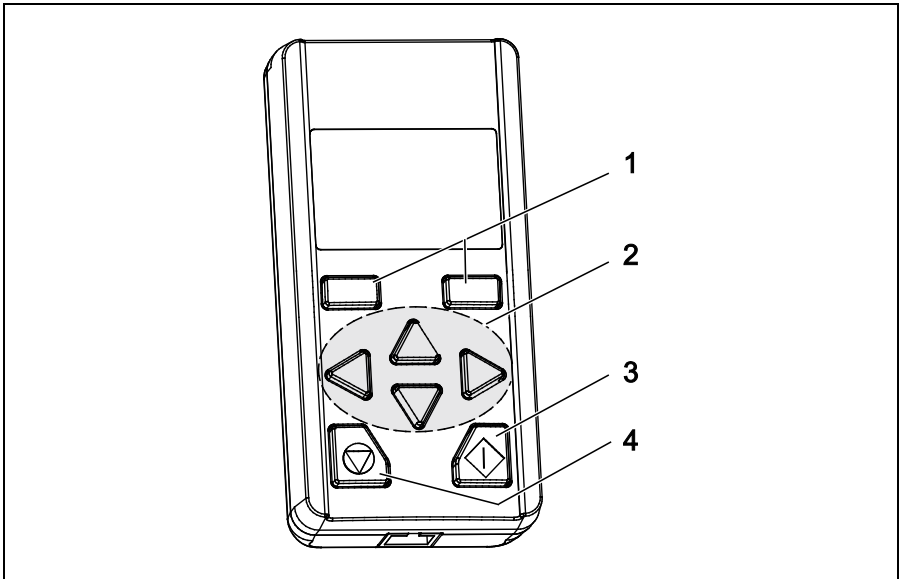

Fig. 4: Button functions

- 1 Confirm buttons
- 2 "UP"/"DOWN" buttons
"LEFT" / "RIGHT" buttons
- 3 Start button
- 4 Stop button

3.2 Navigation and input

| Buttons | Function |
|--|--|
| "UP"/"DOWN" buttons | Selecting parameters, changing values |
| "LEFT"/"RIGHT" arrows | Navigating cursor |
| Confirm buttons | With these buttons, the command showed in the display is activated via the button |
| "START"/"STOP" buttons | With these buttons, the motor is started or stopped |
| Commands | Procedures |
| Next | Calling up parameters and submenu |
| Back | One menu level higher |
| Cancel | End entry without saving |
| Change | Call up edit mode (cursor blinks) |
| Save | Save selection, entry or change |
| Enter | Confirm the selected parameter set |
| Start | Command for motor detection |
| Enter | Procedures |
| Displaying tens, hundreds, thousands place | Press "LEFT" arrow until the desired tens, hundreds or thousands place is displayed. |
| Displaying decimal places | Press "RIGHT" arrow until the desired decimal places are displayed. |
| Entering negative values | Place cursor on the plus sign, select the minus sign with the "UP" arrow and save. |

3.3 Menu

If the INVEOR MMI is connected to the INVEOR and the INVEOR is switched on, the menu appears on the display of the MMI.

For the *Parameter groups* menu, there are two modes:

- Standard mode
contains all necessary parameters for standard application from the factory.
- Expert mode (see menu overview in Chapter 3.6)
Contains advanced parameters for special uses. The expert mode is activated in the main menu (see Fig. 5: View of main menu).

The INVEOR MMI always starts in standard mode. If the INVEOR MMI is de-energized, the standard mode is active again.

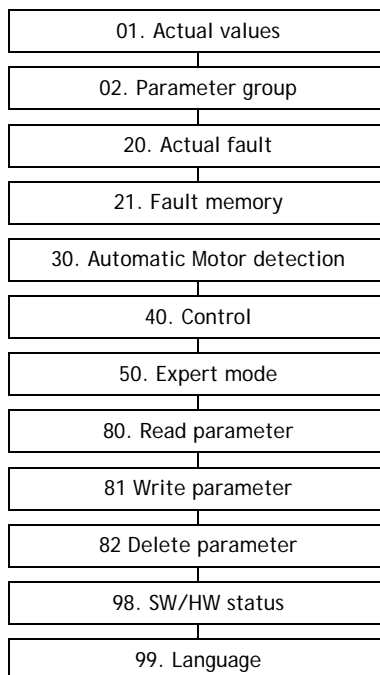

Fig. 5: View of main menu

The entire menu is mapped in the INVEOR operating manual.

3.4 Motor detection

 **DANGER!****RISK OF DEATH DUE TO ROTATING PARTS!**

The motor can rotate during the programming. Depending on the equipment, this can cause a dangerous situation for persons and the equipment.

Make sure that no one is located in hazardous zones and that the motor is disconnected.

 **DANGER!****RISK OF DEATH DUE TO ELECTRIC SHOCK!**

When working on the device, de-energize the device and secure it from being switched on again.

Procedures:

- 1 De-energize drive control.
- 2 Unscrew the four screws from the drive control housing cover and remove the cover.
- 3 For the hardware enable, connect the 24-volt DC hardware to the INVEOR, connect the application board to the "En.HW" terminal.



This voltage can be supplied externally or from the "24V out" terminal. For these, refer to the INVEOR operating manual.

- 4 Screw the cover onto the drive control housing.
- 5 Connect the communication cable to the INVEOR MMI and the INVEOR drive control.
- 6 Switch on the power supply for the drive control.
 - ↳ On the INVEOR MMI display, the start screen appears and then the menu.



The motor type is configured for asynchronous motors (value 1) by default.

For synchronous motors, the value must be changed to 2. (02.Parameter groups (Expert mode)> Motor parameter > Motor type)

7 Determine the following six motor data from the type plate (see example)

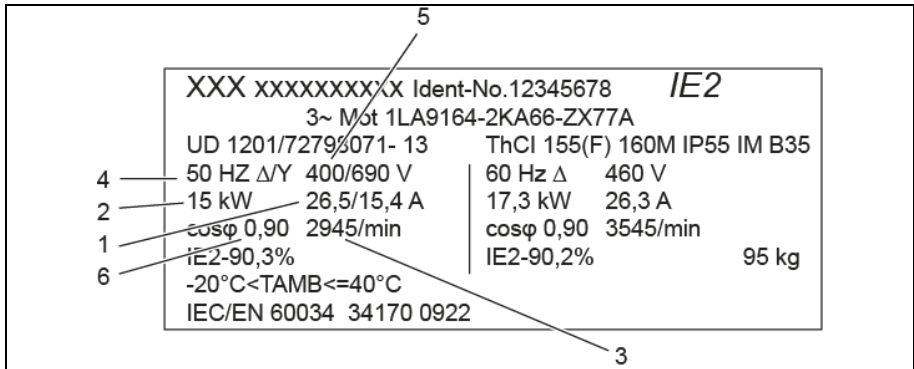
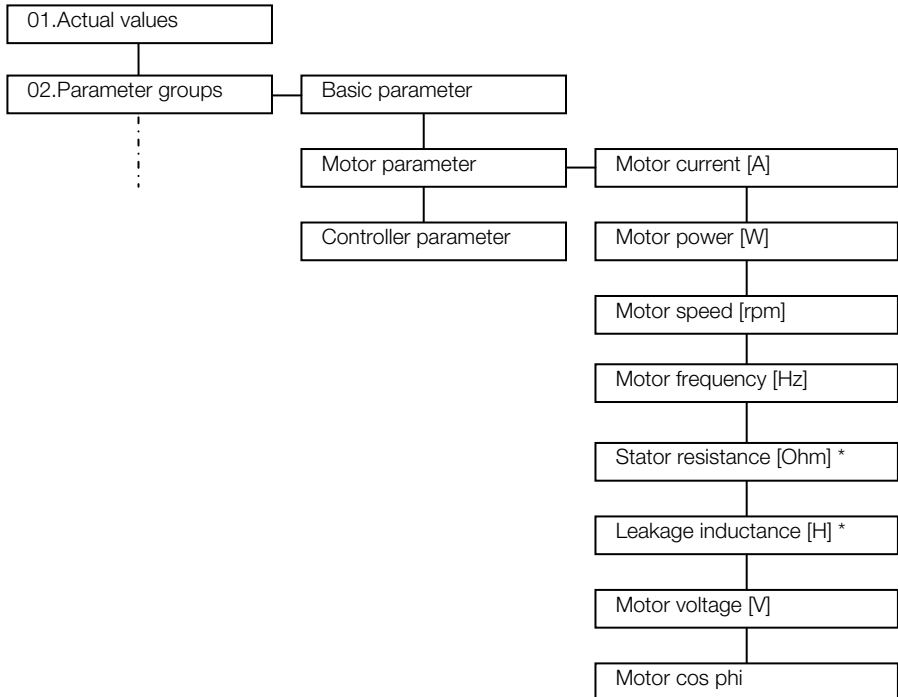

Fig. 6: Motor type plate (example)

| No. | Menu item in the MMI | According to the example on the template |
|-----|----------------------|--|
| 1. | Motor current | 26.5 A |
| 2. | Motor power | 15 kW |
| 3. | Motor speed | 2,945 rpm |
| 4. | Motor frequency | 50 Hz |
| 5. | Motor voltage | 400 V |
| 6. | Motor cosφ | 0.90 |

Tab. 1: Determined motor data for motor detection (example)

- 8 Call up the 02.Parameter groups > Motor data menu.
- 9 Enter and save the six types of motor data from the type plate with the INVEOR MMI under the corresponding menu items. (The values for "stator resistance" and "leakage induct." are determined during motor detection.)



*) These values are automatically determined and entered during motor detection.

Fig. 7: View of menu structure for motor data



Always observe the following during motor detection!

Asynchronous motor: The shaft must not rotate during motor detection.

Synchronous motor: The shaft must be unencumbered since it occasionally rotates during motor detection.

- 10 Call up the 30.*Automatic Motor detection* menu and start motor detection.

↩ Red and green LEDs light up during motor detection



Motor detection lasts 30 - 60 seconds. Motor detection is completed when the INVEOR is restarted and the green LED on INVEOR lights up continuously.



If the INVEOR MMI is unplugged from the M12 interface during the active controlling process, the INVEOR stops with error 21 (Bus Time-Out) and the red LED lights up continuously.

The motor detection is completed.

3.5 Specifying nominal value for the rotation speed

With the INVEOR MMI, a nominal value (in %) can be specified for the rotation speed. This nominal value is specified as a percentage of the nominal motor rotation speed.

The ACTUAL rotation speed can be read on the display. With the "START" and "STOP" button, the motor is switched on and off.



If the minimum frequency is > 0, the motor continues to rotate at the minimum frequency after switching off the nominal value. (02Parameter group (Expert mode)>Basic parameter>Low speed)

Procedures

- 1 As the nominal value source, set "3: MMI/PC" (02.Parameter groups > Basic parameter > Reference channel)
- 2 As the software enable signal, set "9: "Autostart" and save (02.Parameter groups > Basic parameter > Enable software)
- 3 Under the menu item "40.Control", set a nominal value in %. Using the "UP", "DOWN", "LEFT" or "RIGHT" arrows, set the desired percentage.



A negative nominal value causes a change in direction of rotation.

- 4 Press the "START" button and start the motor.
 - ↳ The motor rotates. The actual rotation speed is displayed in the MMI.
 - With the INVEOR MMI, the motor can be switched on and off and a nominal rotation speed can be specified.

3.6 Parameter group menu (expert mode)

In expert mode, the "0.2 Parameter group" menu contains advanced parameters for special applications. The expert mode is activated in the main menu (see Fig. 5: View of main menu).

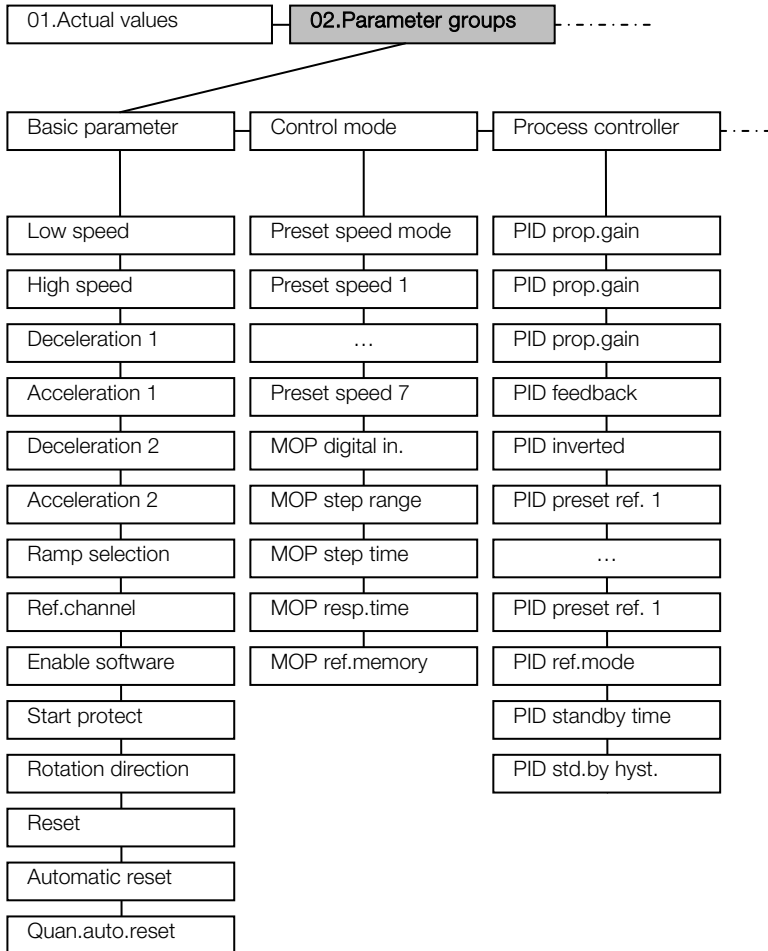

Fig. 8: View of parameter group (expert mode) - Part 1

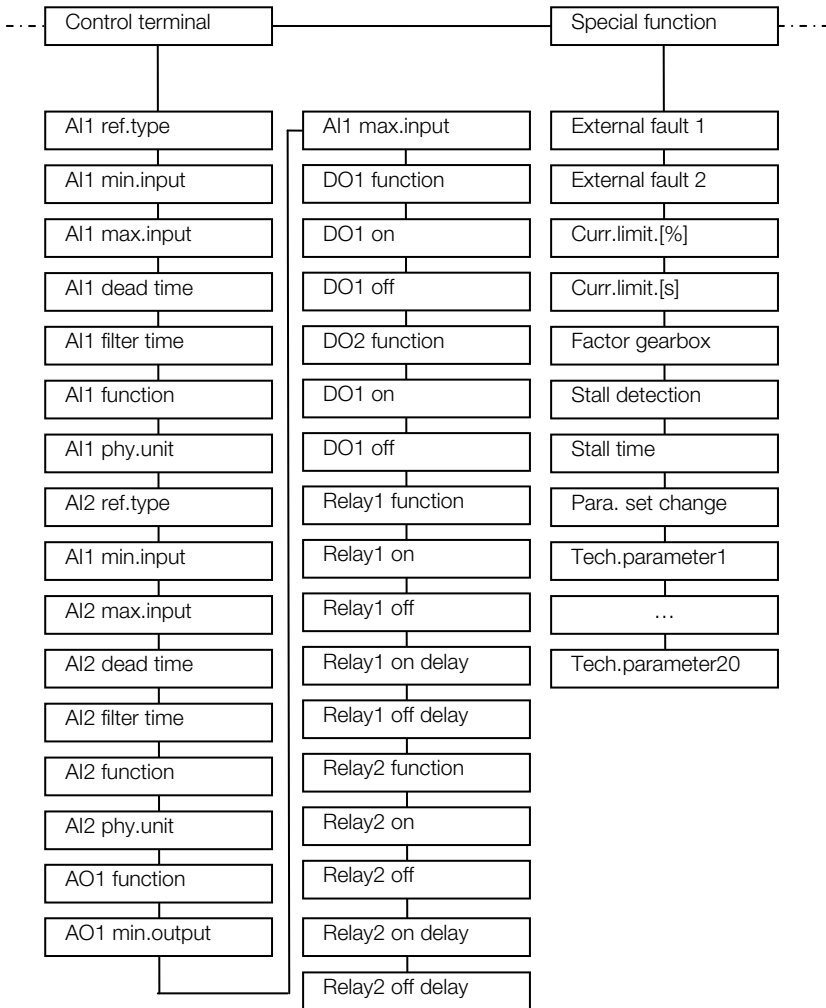
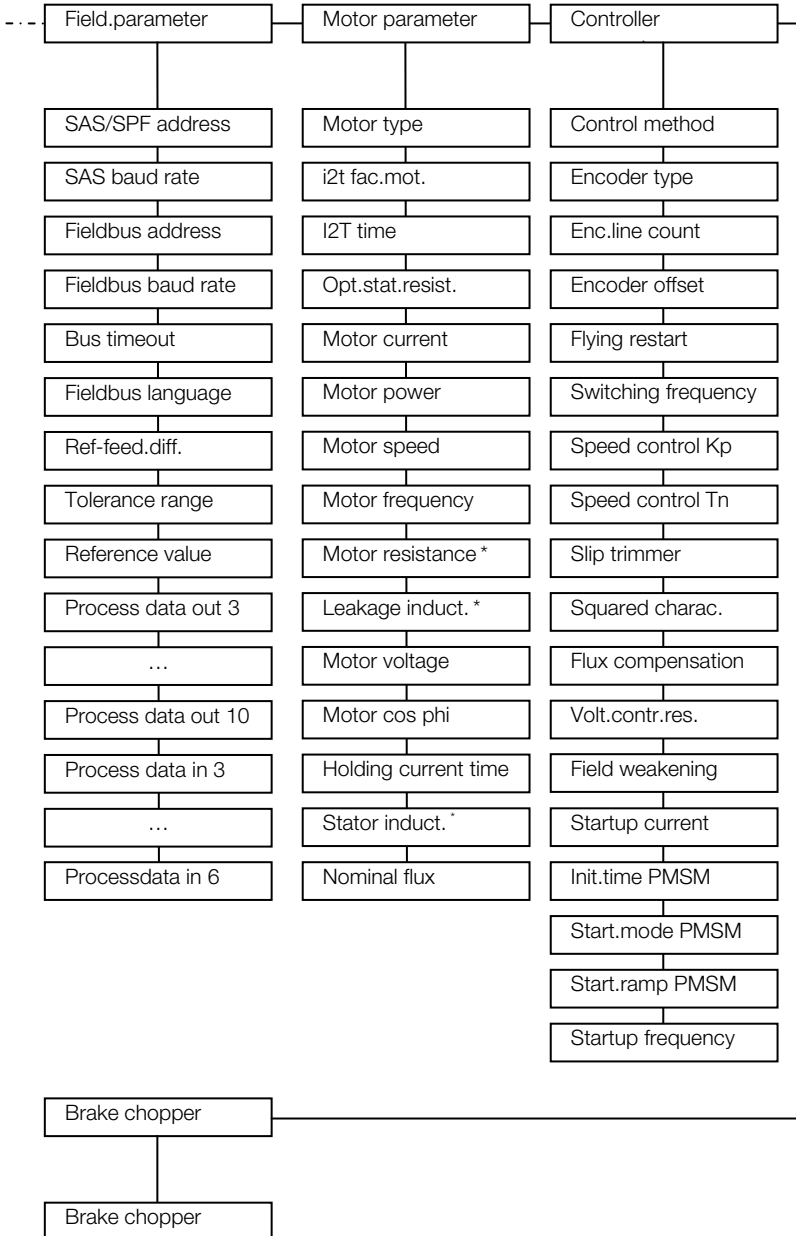

Fig. 9: View of parameter group (expert mode) - Part 2



*) These values are automatically determined and entered during motor detection.

Fig. 10: View of parameter group (expert mode) - Part 3

4 Technical data

| | |
|-------------------------|---------------------|
| Article number | 10004768 |
| Connection cable | 3m RJ11 on M12 plug |
| Measurement (L / W / H) | 105/50/25 mm |
| Weight | 83 g |
| Protection class | IP21 |

Tab. 2: Technical data

5 Approvals, standards and guidelines

This chapter contains information about the respective approvals, standards and guidelines.

For binding information about the particular approvals, please refer to the relevant type plate!

5.1 Standards and guidelines

The following specifically apply:

- Directive on Electromagnetic Compatibility (Directive 2004/108/EC of the Council EN 61800-3:2004)

6 List of key words

| | | | |
|-------------------------------------|----|--------------------------|----|
| C | | S | |
| CE marking..... | 7 | Safety instructions..... | 7 |
| Configuring nominal value | 20 | Standard mode..... | 15 |
| D | | Standards..... | 24 |
| Disposal | 8 | T | |
| E | | Technical data | 24 |
| EC Declaration of Conformity..... | 7 | | |
| EMC limit classes | 24 | | |
| EMC standard | 24 | | |
| Expert mode | 21 | | |
| F | | | |
| Functions of buttons | 13 | | |
| I | | | |
| Information | 10 | | |
| Initial operation | 16 | | |
| L | | | |
| Legal notice..... | 2 | | |
| M | | | |
| Menu | 15 | | |
| Menu structure for motor data... .. | 18 | | |
| N | | | |
| Navigation | 14 | | |
| O | | | |
| Operation | 13 | | |
| P | | | |
| Parameter group (expert mode) . | 21 | | |
| Parametrisation | 5 | | |
| Proper use..... | 8 | | |
| R | | | |
| Regulations | 8 | | |

7 Notes

10108839

KOSTAL

KOSTAL Industrie Elektrik GmbH
Lange Eck 11
58099 Hagen
Deutschland
www.kostal.com/industrie

Telefon: +49 2331 8040-4800
Telefax: +49 2331 8040-4811