

# Goodrive20-EU Series

General Purpose Vector Control Inverter

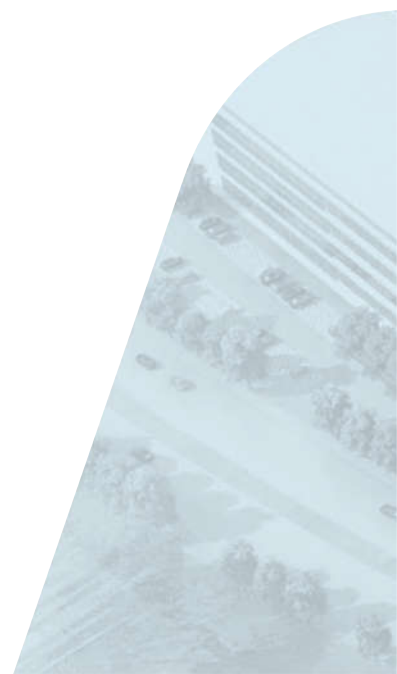

<b>Introduction</b> .....	2
<b>Features</b> .....	3
Optimized structure design .....	3
Excellent performance .....	4
Multi-function and easy to use.....	5
Reliable QA.....	8
<b>Applications</b> .....	9
<b>Technical specifications</b> .....	10
<b>Selection</b> .....	11
Type designation key .....	11
Rated parameters .....	11
<b>Standard wiring</b> .....	12
<b>Installation dimension</b> .....	13
<b>Optional parts</b> .....	17

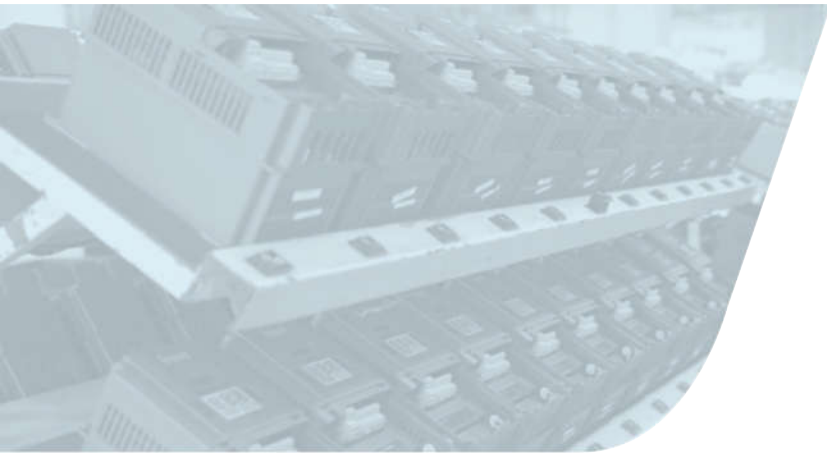



## / Introduction

Goodrive20-EU is a general purpose vector control inverter with certified STO (Safe Torque OFF) function. It's oriented for OEM equipment markets, mainly covering the applications of water treatment, printing and packaging, winding equipment, paper machinery, shearing equipment, plastic machinery, food machinery, cable machinery, textile machinery, HVAC, etc.



## Main Features

1. V/F and Sensorless Vector Control
2. External keypad for parameters copy
3. Common DC bus solution (400V;  $\geq 4\text{kW}$ )
4. Starting torque up to 0.5Hz/150%
5. Built-in DC reactor for inverters  $\geq 18.5\text{kW}$
6. Built-in braking unit (standard  $\leq 37\text{kW}$ , optional  $\geq 45\text{kW}$ )
7. Standard C3 filter ( $\geq 4\text{kW}$ ), optional C3 filter ( $\leq 2.2\text{kW}$ ) and C2 Filter

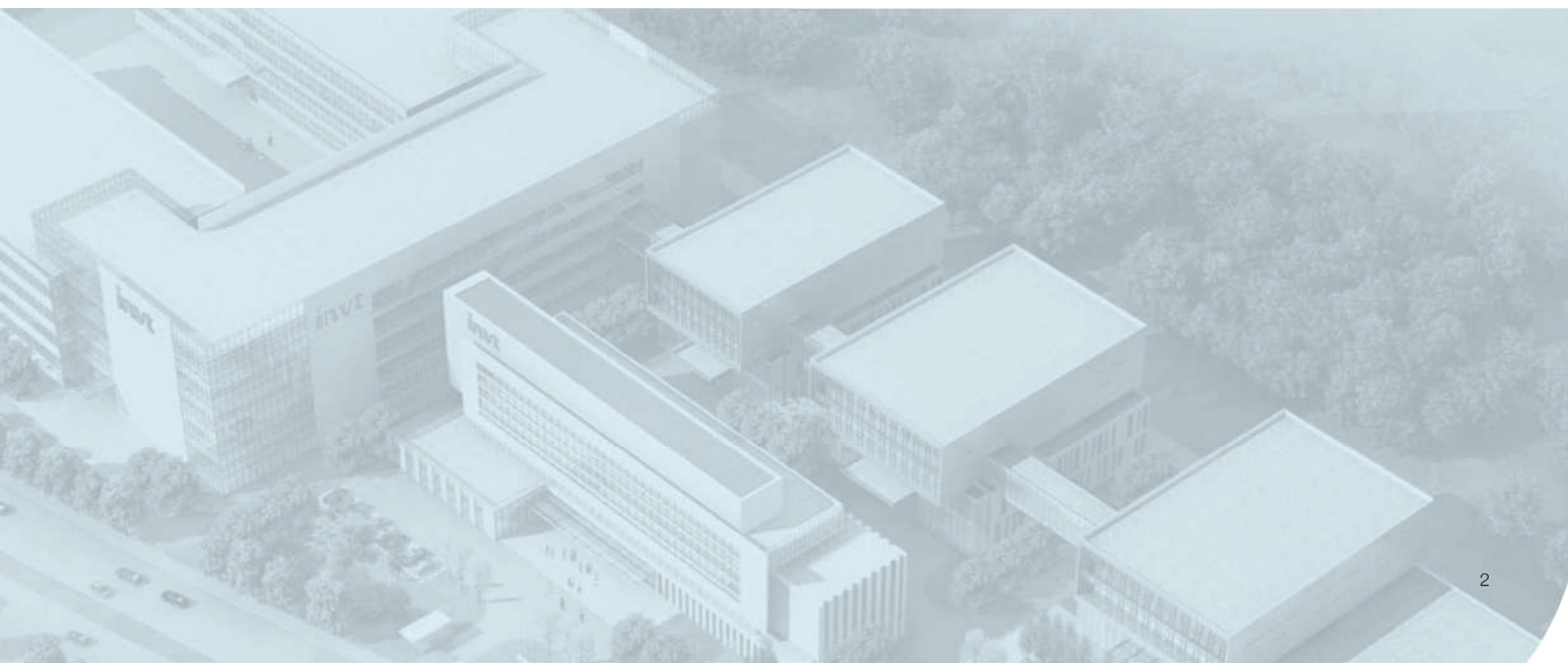

## Features

Mini design for inverters ( $\leq 2.2\text{kW}$ ); side by side installation of multiple inverters, reducing installation space



### Flexible installation ways

Inverters ( $\leq 2.2\text{kW}$ ) support wall mounting and rail mounting.



Rail mounting



Wall mounting

Inverters ( $\geq 4\text{kW}$ ) support wall mounting and flange mounting.



## Excellent Performance

Excellent vector control performance

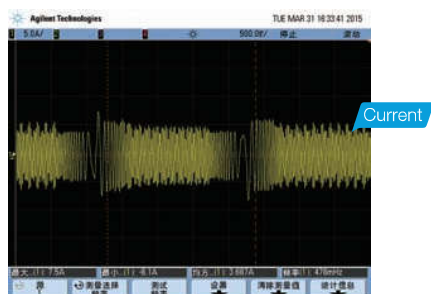

Current waveforms in vector control mode with 50Hz and full load

## Excellent motor drive performance

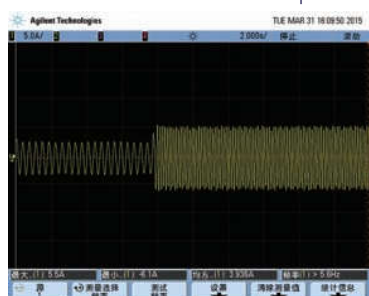

Current waveforms when sudden loading in V/F control mode with 2Hz and full load

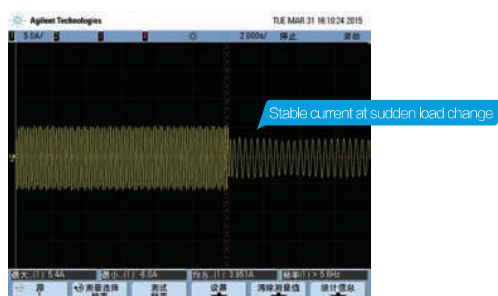

Current waveforms when sudden unloading in V/F control mode with 2Hz and full load

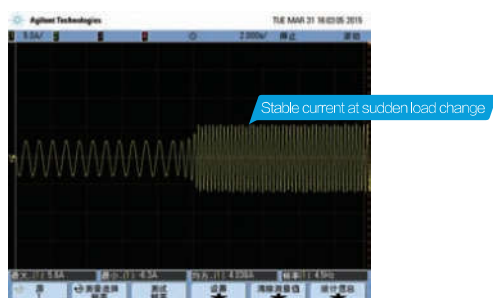

Current waveforms when sudden loading in vector control mode with 0.5Hz and full load

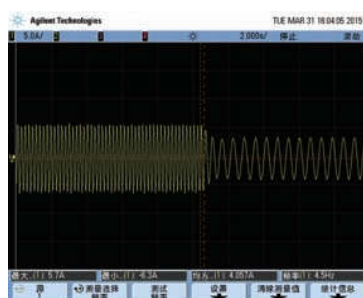

Current waveforms when sudden unloading in vector control mode with 0.5Hz and full load

## Excellent high frequency running performance

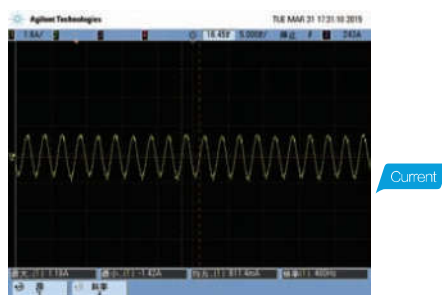

Current waveforms when sudden loading in vector control mode with 0.5Hz and full load

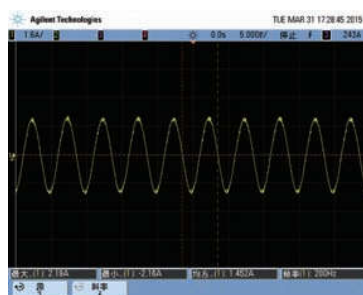

Current waveforms when sudden unloading in vector control mode with 0.5Hz and full load

## Multi-function and easy to use

Built-in DC reactor for inverter  $\geq 18.5\text{kW}$



The braking unit is built-in and standard for inverters  $\leq 37\text{kW}$  but optional for inverter of 45-110kW.



Inverter (400V;  $\geq 4\text{kW}$ ) support the Common DC bus solution.

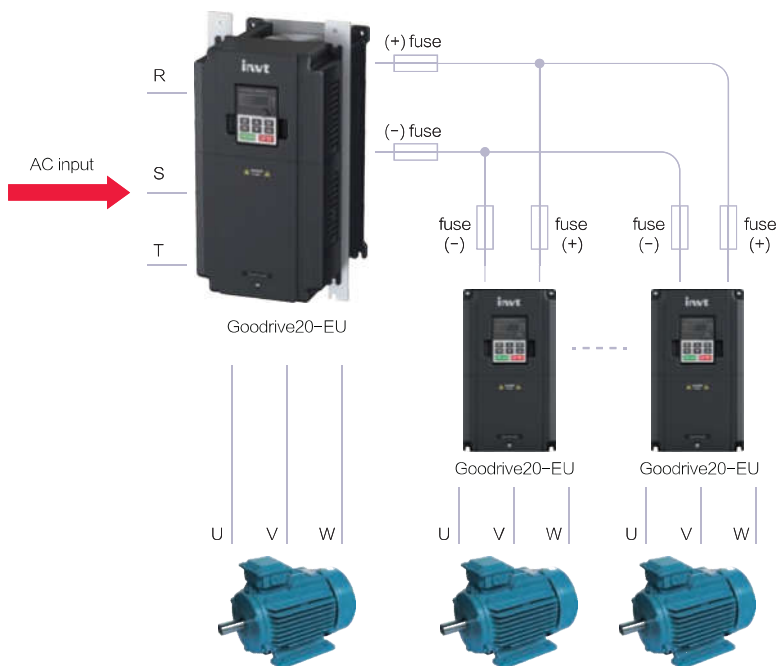

## Built-in Safe Torque Off function

Model	Certification standard and level		
	IEC 61508	EN/ISO 13849-1	EN954-1
-S2:0.4~2.2kW -2:0.4~0.75kW -4:0.75~2.2kW	SIL2	PLd	Category3
-2:1.5~7.5kW -4:4~110kW	SIL3	PLe	Category3

## C3 and C2 filters

C3 filters are built in inverters (3PH; 400V;  $\geq 4$ kW) and (3PH; 230V;  $\geq 1.5$ kW) by using J10 to determine the connection or disconnection. External C3 filters can be configured for inverters (1PH; 230V;  $\leq 2.2$ kW), (3PH; 400V;  $\leq 2.2$ kW) and (3PH; 230V;  $\leq 0.75$ kW).

External C2 filters are optional for all GD20-EU series inverters.

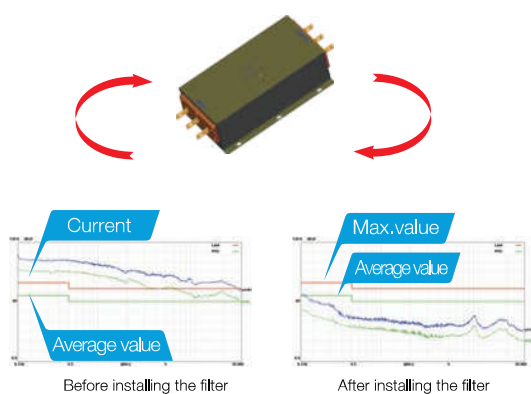

Conductive interference test of the power supply terminals

Remarks:

C2 filter: EMC performance of the inverter achieves the limited usage requirement in civil environment.

C3 filter: EMC performance of the inverter achieves the limited usage requirement in industrial environment.

## External keypad

The membrane keypad are standard for inverters (3PH; 400V;  $\leq 2.2$ kW), which also support external LED keypads. The keypads for inverters (3PH; 400V;  $\geq 4$ kW) can be used as external keypads.

GD20-EU series inverters can be configured with LED keypad which has the data copy function to upload or download the parameters.



Pluggable design for cooling fans, easy maintenance



## Abundant Software Functions

Function	Used to	Remarks
RS485 communication	Read and modify inverter parameters through connection to the upper computer so as to control inverter running status.	Configured with RS485 communication interface
PID	Carry out PID operation on feedback signals to control inverter output frequency and improve target accuracy and stability. Applicable to pressure, flow and temperature process control.	Supports PID output polarity switching.
Motor parameter autotuning	Carry out rotation or static autotuning, improving control accuracy and response speed.	Classified into rotation autotuning and static autotuning.
Simple PLC function	Change the running frequency and direction automatically according to the running time set by simple PLC to meet process requirements.	Supports multiple running modes.
Multi-step speed control	Meet the speed control requirements in different periods of time.	A maximum of 16 steps can be divided for multi-step speed control.
Multiple V/F curve settings	Meet the requirements of energy-saving operation for fans and water pumps and of various variable frequency power supplies; adapt to different load applications.	Linear, multi-dot, multi-power and V/F separation settings, implementing flexible setting of V/F curves.
Virtual terminals	Take external signals as local virtual I/O to reduce hardware configuration.	Corresponding virtual terminal functions must be enabled in communication mode.
Delay of switching on and off	Provide more programming and control modes	Max. switching on/off delay is 50s
Uninterrupted running in instantaneous power off	Ensure uninterrupted running in instantaneous power off. Especially applicable to the situations with high requirements on continuous operation.	At transient voltage drop, the inverter can keep running by feedback energy without stop in valid time.
Various protection functions	Provide overall fault protection functions.	Various measures provided to protect against faults such as overcurrent, overvoltage, undervoltage, overheating, and overload, whose information can be saved.
Multiple braking modes available	Provide multiple braking modes, satisfying accurate and quick stop under different loads.	DC braking, flux braking, dynamic braking
Battery capacity display	Display the accumulative power consumption on the inverter without watt-hour meter.	Inverter power consumption can be queried.



## Reliable QA

Perfect and Reliable Test System Ensure Products Adapt Complicated Site Environments and Achieved ACT Certificate of TÜV SÜD

Experiment Type	Experiment Name	Classification
Mechanical Reliability Experiments	Packaging Experiments	Package compression experiments
		Package Resonance imaging and storage test
		Package random vibration test
		Package dropping test
		Package rolling test
		Package dumping test
		Package inclined impact test
	Impact Test	Half-sine shock test(working and non-working state)
		Trapezoidal wave impulse test(non-working state)
	Vibration Test	Sinusoidal vibration test(working state)
Random vibration test(working and non-working state)		
Climatic Environmental Reliability Test	Temperature Experiment	Low temperature storage test
		High temperature storage test
		Low temperature working test
		High temperature working test
		Gradient temperature change test
		Temperature impact test
	Temperature Humidity Test	Constant temperature&humidity test
		Alternation temperature&humidity test
	Salt Spray Test	Constant salt spray test
		Alternation salt spray test
	Low Air Pressure Test	Combined dry heat&low air pressure test
		Combined cold&low air pressure test

Remarks:

The full name of ACT is Acceptance of Client's Testing, which means the German TÜV SÜD admit the technology level of the lab and accept their separate testing data and test reports officially.



Electric Vibration System



Low Pressure Test Chamber & Constant temperature and humidity test chamber



Faster temperature chamber & Thermal Shock Test Chamber

# Applications

Textile machinery



Food machinery



Plastic machinery



Printing and packaging



Environmental protection equipment



Ceramic equipment



Woodworking equipment



Conveying equipment



Air compressor



Cable machinery



# Technical specification

Function		Specification
Power Input	Input Voltage (V)	1PH 220V (-15%)~240V(+10%) 3PH 220V(-15%)~240V(+10%) 3PH 380V (-15%)~440V(+10%)
	Input Current (A)	Refer to the rated value
	Input Frequency (Hz)	50Hz or 60Hz, allowed range: 47~63Hz
Power Output	Output Motor Capacity (kW)	Refer to the rated value
	Output Current (A)	Refer to the rated value
	Output Voltage (V)	0~input voltage, error<5%
	Output Frequency (Hz)	0~400Hz
Technical Control Feature	Control Mode	SVPWM, SVC
	Adjustable-speed Ratio	1:100
	Speed Control Accuracy	± 0.2% (SVC)
	Speed Fluctuation	± 0.3% (SVC)
	Torque Response	<20ms (SVC)
	Torque Control Accuracy	10%
	Starting Torque	0, 5Hz/150% (SVC)
Running Control Feature	Overload Capability	150% of rated current: 1 minute 180% of rated current: 10 seconds 200% of rated current: 1 second
	Frequency Setting Method	Digital setting, analog setting, pulse frequency setting, multi-step speed running setting, simple PLC setting, PID setting, MODBUS communication setting Shift between the set combination and set channel.
	Auto-adjustment of the Voltage	Keep a stable voltage automatically when the grid voltage transients
Peripheral Interface	Fault Protection	Provide comprehensive fault protection functions: over-current, over-voltage, under-voltage, over-heating, phase loss and overload, etc.
	Analog Input	1 (AI2) 0~10V/0~20mA and 1 (AI3) -10~10V
	Analog Output	2 (AO1, AO2) 0~10V/0~20mA (Only 1 AO for inverters ≤2.2kW)
	Digital Input	4 common inputs, the Max. frequency: 1kHz; 1 high speed input, the Max. frequency: 50kHz
	Digital Output	1 Y1 terminal output;
Others	Relay Output	2 programmable relay outputs(Only 1 Relay output for inverters ≤2.2kW) RO1A NO, RO1B NC, RO1C common terminal RO2A NO, RO2B NC, RO2C common terminal Contactor capacity: 3A/AC250V
	Mountable Method	Wall and rail mountable
	Braking Unit	≤37kW Standard built-in, 45~110kW Optional built-in (model "-B")
	EMI Filter	Optional filter: meet the degree requirement of IEC61800-3 C2, IEC61800-3 C3
	Temperature of the Running Environment	-10~50°C Above 40°C, derate 1% for every additional 1°C.
	Altitude	<1000m Above 1000m, derate 1% for every additional 100m.
	Protective Degree	IP20
	Safety	Meet the requirement of CE
Cooling	Fan cooling	

# Selection

## Type designation key

### GD20-055G-4-B-EU

①                      ②                      ③                      ④                      ⑤

Key	No.	Detailed description	Detailed content
Abbreviation	①	Product abbreviation	GD20-EU is short for Goodrive20-EU
Rated power	②	Power range+load type	055:55kW G: constant torque load
Voltage degree	③	Voltage degree	S2: AC 1PH 220V(-15%)-240V(+10%) 2: AC 3PH 220V(-15%)-240V(+10%) 4: AC 3PH 380V(-15%)-440V(+10%)
Additional information 1	④	Braking unit	B: For inverter $\geq 45$ kW and With "B" assigned, means built-in braking unit.
Additional information 2	⑤	Special function	EU: built-in Safe Torque Off function; Without EU, without the function

## Rated parameters

Model	Voltage degree	Output power (kW)	Input current (A)	Output current (A)	STO function
GD20-0R4G-S2-EU	1PH 230V	0,4	6,5	2,5	Class SIL2 PLd CAT,3
GD20-0R7G-S2-EU		0,75	9,3	4,2	
GD20-1R5G-S2-EU		1,5	15,7	7,5	
GD20-2R2G-S2-EU		2,2	24	10	
GD20-0R4G-2-EU	3PH 230V	0,4	3,7	2,5	Class SIL3 PLe CAT,3
GD20-0R7G-2-EU		0,75	5	4,2	
GD20-1R5G-2-EU		1,5	7,7	7,5	
GD20-2R2G-2-EU		2,2	11	10	
GD20-004G-2-EU		4	17	16	
GD20-5R5G-2-EU		5,5	21	20	
GD20-7R5G-2-EU		7,5	31	30	
GD20-0R7G-4-EU	3PH 400V	0,75	3,4	2,5	Class SIL3 PLe CAT,3
GD20-1R5G-4-EU		1,5	5,0	4,2	
GD20-2R2G-4-EU		2,2	5,8	5,5	
GD20-004G-4-EU		4	13,5	9,5	
GD20-5R5G-4-EU		5,5	19,5	14	
GD20-7R5G-4-EU		7,5	25	18,5	
GD20-011G-4-EU		11	32	25	
GD20-015G-4-EU		15	40	32	
GD20-018G-4-EU		18,5	47	38	
GD20-022G-4-EU		22	51	45	
GD20-030G-4-EU		30	70	60	
GD20-037G-4-EU		37	80	75	
GD20-045G-4-EU		45	98	92	
GD20-045G-4-B-EU		45	98	92	
GD20-055G-4-EU		55	128	115	
GD20-055G-4-B-EU		55	128	115	
GD20-075G-4-EU		75	139	150	
GD20-075G-4-B-EU		75	139	150	
GD20-090G-4-EU		90	168	180	
GD20-090G-4-B-EU		90	168	180	
GD20-110G-4-EU		110	201	215	
GD20-110G-4-B-EU		110	201	215	

# Standard wiring

## Wiring diagram of control circuit

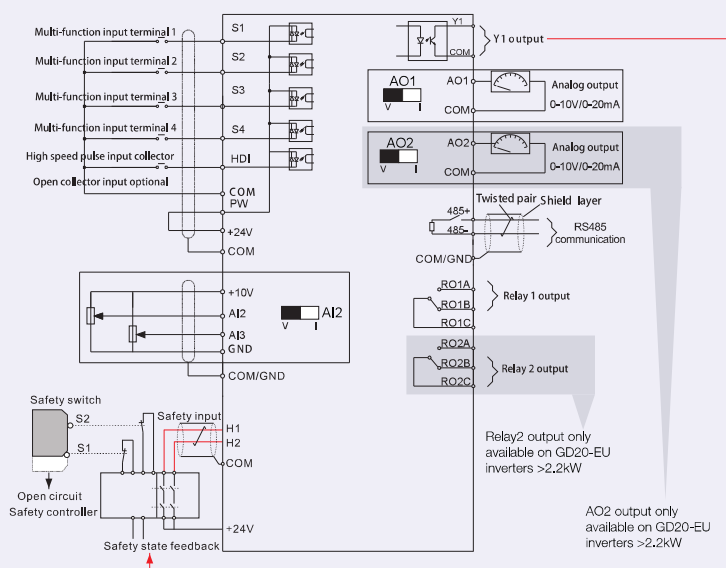

## Logic table for STO function

Input states and corresponding faults of STO function:

STO input state	Corresponding STO fault
H1, H2 opens simultaneously	Trigger STO function, the drive can't operate normally
H1, H2 closes simultaneously	Don't trigger STO function, the drive can operate normally
Either H1 or H2 opens or closes	Trigger STL1/STL2/STL3 fault, fault code: 38: Safety circuit of channel 1 is abnormal (STL1) 39: Safety circuit of channel 2 is abnormal (STL2) 40: Internal circuit is abnormal (STL3)

Control terminal diagram

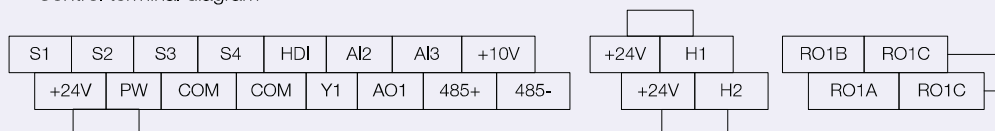

Fig 1 Connection terminal diagram for inverters ≤ 2.2kW

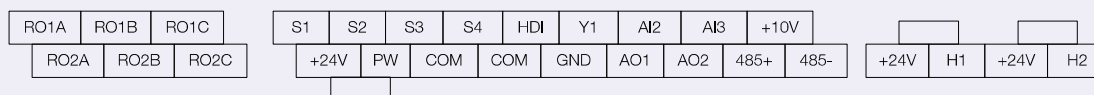
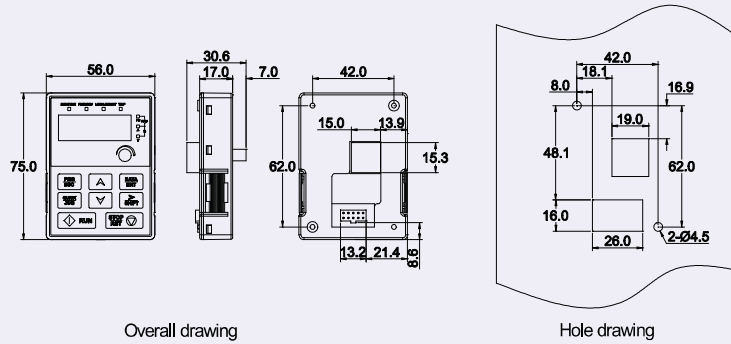

Fig 2 Connection terminal diagram for inverters ≥ 4kW

# Installation dimension

## External keypad dimension



Overall drawing

Hole drawing

Note: The external keypad can be 20 meters away from the inverter at most.

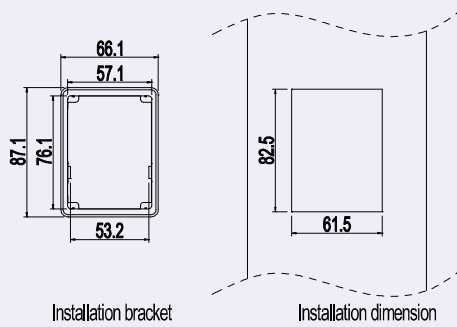

Installation bracket

Installation dimension

## Inverter dimension

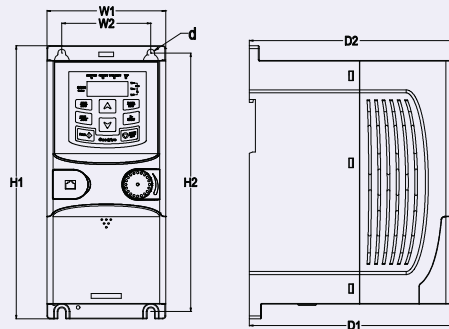

Wall mounting of 0.75~2.2kW inverters

Dimension (unit: mm)

Model	W1	W2	H1	H2	D1	D2	Hole (d)
GD20-0R4G-S2-EU	80,0	60,0	160,0	150,0	123,5	120,3	5
GD20-0R7G-S2-EU	80,0	60,0	160,0	150,0	123,5	120,3	5
GD20-1R5G-S2-EU	80,0	60,0	185,0	175,0	140,5	137,3	5
GD20-2R2G-S2-EU	80,0	60,0	185,0	175,0	140,5	137,3	5
GD20-0R4G-2-EU	80,0	60,0	185,0	175,0	140,5	137,3	5
GD20-0R7G-2-EU	80,0	60,0	185,0	175,0	140,5	137,3	5
GD20-0R7G-4-EU	80,0	60,0	185,0	175,0	140,5	137,3	5
GD20-1R5G-4-EU	80,0	60,0	185,0	175,0	140,5	137,3	5
GD20-2R2G-4-EU	80,0	60,0	185,0	175,0	140,5	137,3	5

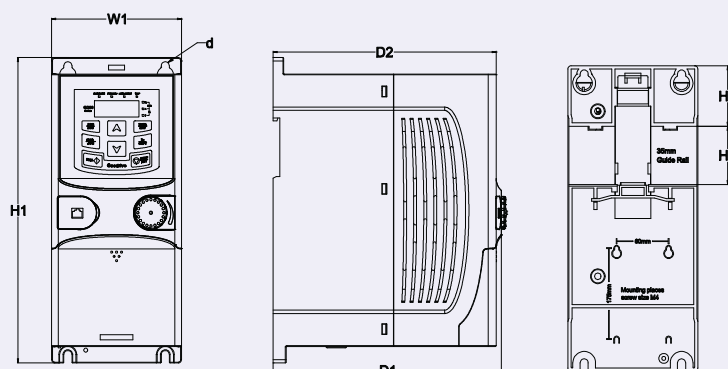

Rail mounting of inverters of 1PH 230V/3PH 400V ( $\leq 2.2\text{kW}$ ) and 3PH 230V ( $\leq 0.75\text{kW}$ )

Dimension (unit: mm)

Model	W1	W2	H1	H2	D1	D2	Hole (d)
GD20-0R4G-S2-EU	80,0	160,0	35,4	36,6	123,5	120,3	5
GD20-0R7G-S2-EU	80,0	160,0	35,4	36,6	123,5	120,3	5
GD20-1R5G-S2-EU	80,0	185,0	35,4	36,6	140,5	137,3	5
GD20-2R2G-S2-EU	80,0	185,0	35,4	36,6	140,5	137,3	5
GD20-0R4G-2-EU	80,0	185,0	35,4	36,6	140,5	137,3	5
GD20-0R7G-2-EU	80,0	185,0	35,4	36,6	140,5	137,3	5
GD20-0R7G-4-EU	80,0	185,0	35,4	36,6	140,5	137,3	5
GD20-1R5G-4-EU	80,0	185,0	35,4	36,6	140,5	137,3	5
GD20-2R2G-4-EU	80,0	185,0	35,4	36,6	140,5	137,3	5

# Installation dimension

## Inverter dimension

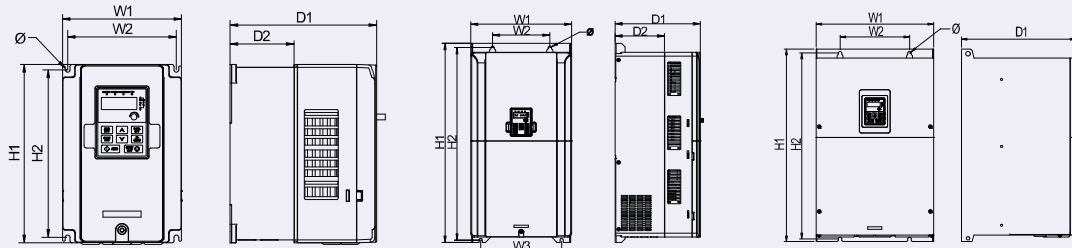

Wall mounting of 3PH 400V 4~37kW and 3PH 230V 1.5~7.5 kW inverters

Wall mounting of 3PH 400V 45~75kW inverters

Wall mounting of 3PH 400V 90~110kW inverters

Dimension (unit: mm)

Model	W1	W2	W3	H1	H2	D1	D2	Hole (d)
GD20-1R5G-2-EU	146.0	131.0	—	256.0	243.5	167.0	84.5	6
GD20-2R2G-2-EU	146.0	131.0	—	256.0	243.5	167.0	84.5	6
GD20-004G-2-EU	146.0	131.0	—	256.0	243.5	167.0	84.5	6
GD20-5R5G-2-EU	170.0	151.0	—	320.0	303.5	196.3	113.0	6
GD20-7R5G-2-EU	170.0	151.0	—	320.0	303.5	196.3	113.0	6
GD20-004G-4-EU	146.0	131.0	—	256.0	243.5	167.0	84.5	6
GD20-5R5G-4-EU	146.0	131.0	—	256.0	243.5	167.0	84.5	6
GD20-7R5G-4-EU	170.0	151.0	—	320.0	303.5	196.3	113.0	6
GD20-011G-4-EU	170.0	151.0	—	320.0	303.5	196.3	113.0	6
GD20-015G-4-EU	170.0	151.0	—	320.0	303.5	196.3	113.0	6
GD20-018G-4-EU	200.0	185.0	—	340.6	328.6	184.3	104.5	6
GD20-022G-4-EU	200.0	185.0	—	340.6	328.6	184.3	104.5	6
GD20-030G-4-EU	250.0	230.0	—	400.0	380.0	202.0	123.5	6
GD20-037G-4-EU	250.0	230.0	—	400.0	380.0	202.0	123.5	6
GD20-045G-4-EU	282.0	160.0	226.0	560.0	542.0	238.0	138.0	9
GD20-055G-4-EU	282.0	160.0	226.0	560.0	542.0	238.0	138.0	9
GD20-075G-4-EU	282.0	160.0	226.0	560.0	542.0	238.0	138.0	9
GD20-090G-4-EU	338.0	200.0	—	554.0	535.0	329.2	—	9.5
GD20-110G-4-EU	338.0	200.0	—	554.0	535.0	329.2	—	9.5

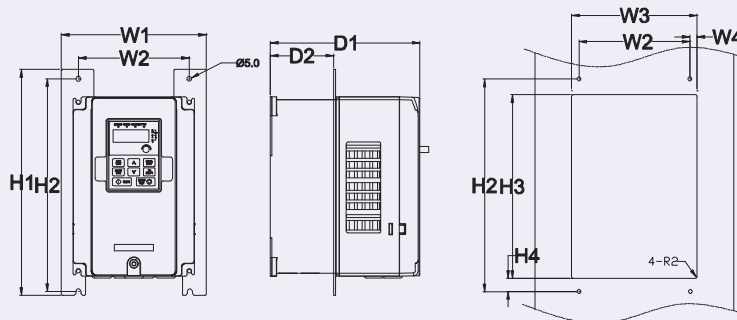

Flange mounting of 3PH 400V 4~75kW and 3PH 230V 1.5~7.5kW inverters



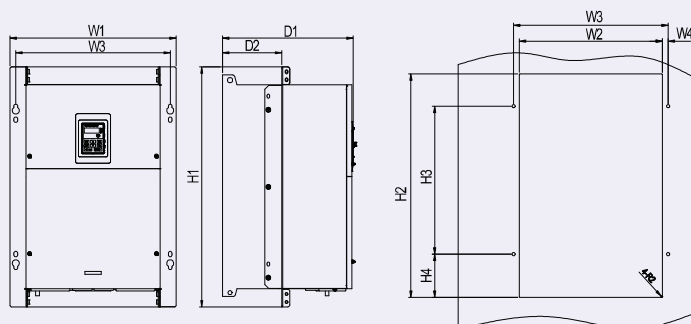

Flange mounting of 3PH 400V 90~110kW inverters

Dimension (unit: mm)

Model	W1	W2	W3	W4	H1	H2	H3	H4	D1	D2	Hole (d)	Nut
GD20-1R5G-2-EU	170.2	131	150	9.5	292	276	260	6	167	84.5	6	M5
GD20-2R2G-2-EU	170.2	131	150	9.5	292	276	260	6	167	84.5	6	M5
GD20-004G-2-EU	170.2	131	150	9.5	292	276	260	6	167	84.5	6	M5
GD20-5R5G-2-EU	191.2	151	174	11.5	370	351	324	12	196.3	113	6	M5
GD20-7R5G-2-EU	191.2	151	174	11.5	370	351	324	12	196.3	113	6	M5
GD20-004G-4-EU	170.2	131	150	9.5	292	276	260	6	167	84.5	6	M5
GD20-5R5G-4-EU	170.2	131	150	9.5	292	276	260	6	167	84.5	6	M5
GD20-7R5G-4-EU	191.2	151	174	11.5	370	351	324	12	196.3	113	6	M5
GD20-011G-4-EU	191.2	151	174	11.5	370	351	324	12	196.3	113	6	M5
GD20-015G-4-EU	191.2	151	174	11.5	370	351	324	12	196.3	113	6	M5
GD20-018G-4-EU	266	250	224	13	371	250	350.6	20.3	184.6	104	6	M5
GD20-022G-4-EU	266	250	224	13	371	250	350.6	20.3	184.6	104	6	M5
GD20-030G-4-EU	316	300	274	13	430	300	410	55	202	118.3	6	M5
GD20-037G-4-EU	316	300	274	13	430	300	410	55	202	118.3	6	M5
GD20-045G-4-EU	352	332	306	13	580	400	570	80	238	133.8	9	M8
GD20-055G-4-EU	352	332	306	13	580	400	570	80	238	133.8	9	M8
GD20-075G-4-EU	352	332	306	13	580	400	570	80	238	133.8	9	M8
GD20-090G-4-EU	418.5	361	389.5	14.2	600	559	370	108.5	329.5	149.5	9.5	M8
GD20-110G-4-EU	418.5	361	389.5	14.2	600	559	370	108.5	329.5	149.5	9.5	M8
GD20-022G-4-EU	200.0	185.0	—	340.6	328.6	184.3	184.3	104.5	184.3	104.5	6	184.3
GD20-030G-4-EU	250.0	230.0	—	400.0	380.0	202.0	202.0	123.5	202.0	123.5	6	202.0
GD20-037G-4-EU	250.0	230.0	—	400.0	380.0	202.0	202.0	123.5	202.0	123.5	6	202.0
GD20-045G-4-EU	282.0	160.0	226.0	560.0	542.0	238.0	238.0	138.0	238.0	138.0	9	238.0
GD20-055G-4-EU	282.0	160.0	226.0	560.0	542.0	238.0	238.0	138.0	238.0	138.0	9	238.0
GD20-075G-4-EU	282.0	160.0	226.0	560.0	542.0	238.0	238.0	138.0	238.0	138.0	9	238.0
GD20-090G-4-EU	338.0	200.0	—	554.0	535.0	329.2	329.2	—	329.2	—	9.5	329.2
GD20-110G-4-EU	338.0	200.0	—	554.0	535.0	329.2	329.2	—	329.2	—	9.5	329.2

Note: In flange installation mode, the installation bracket is optional

# Optional parts

## External LED keypad

Including the external keypads with or without the parameter copying function.



parameter copying

## Reactor

Input reactor: Improve the power factor of the input side of the inverter and control the higher harmonic current.

Output reactor: Prolong the effective transmitting distance of the inverter and control the sudden high voltage when switching on/off the IGBT of the inverter.



## Filter

Input filter: Control the electromagnetic interference generated from the inverter, please install close to the input terminal side of the inverter.

Output filter: Control the interference from the output side of the inverter, please install close to the output terminals of the inverter.



## Braking resistor

Auxiliary equipment for braking system, shorten the deceleration time.



## Membrane of heat releasing holes at the side

Apply to severe environment and improve protective effect.

Derate 10% of the machine.



## Keypad Bracket

Use it to install the keypad on the front of cabinet



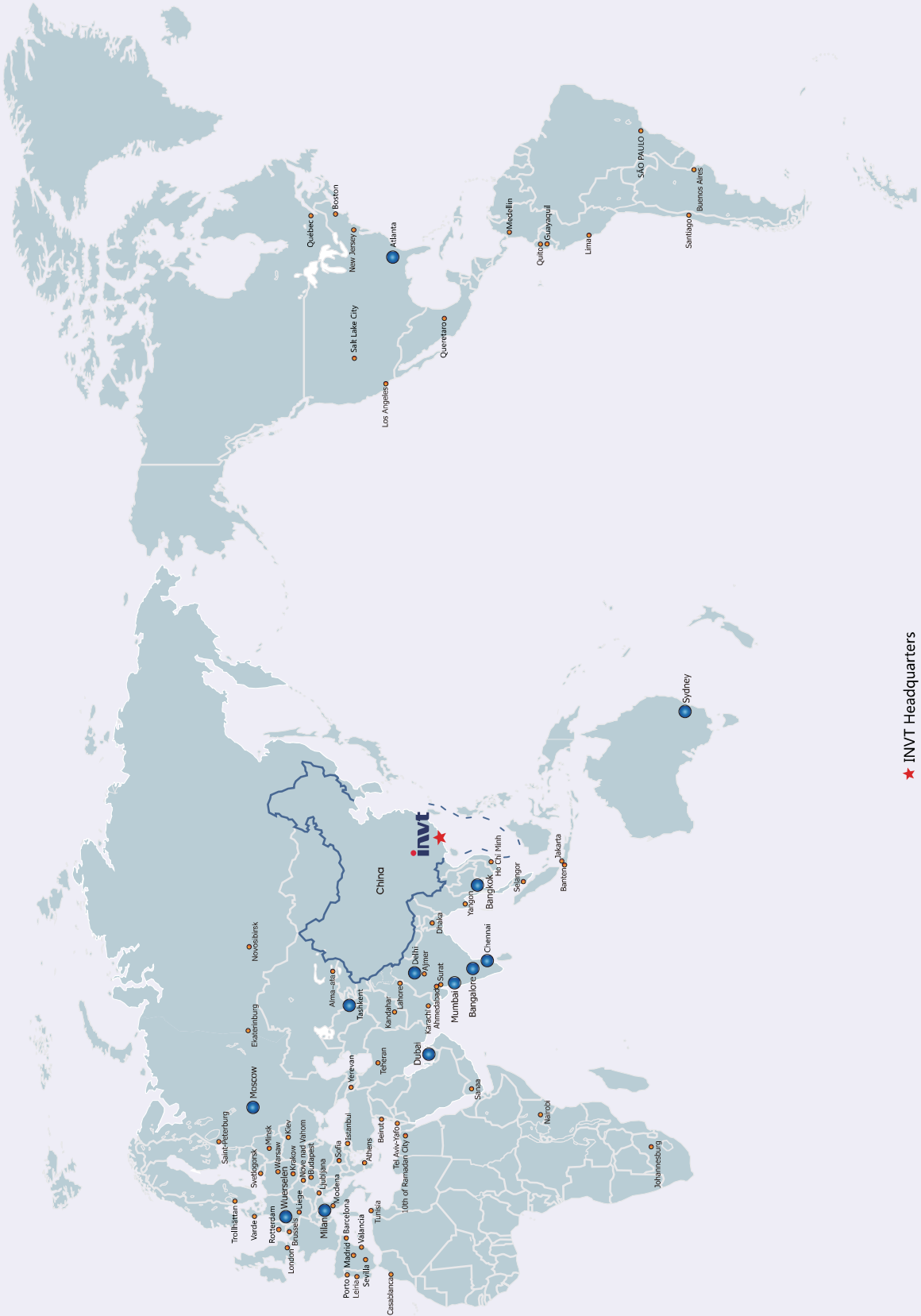

- ★ INVT Headquarters
- INVT Sales & Service in 12 countries
- Sales and Service Partners in 63 countries

*Your Trusted Industry Automation Solution Provider*



Service line:86-755-86312859 E-mail:overseas@invt.com.cn

**SHENZHEN INVT ELECTRIC CO., LTD.**

No.4 Building, Gaofa Scientific Industrial Park, Longjing, Nanshan District, Shenzhen, China

- |                               |  |                                       |                            |                                   |
|-------------------------------|--|---------------------------------------|----------------------------|-----------------------------------|
| <b>Industrial Automation:</b> | • Frequency Inverter                         | • Servo & Motion Control              | • Motor & Electric Spindle | • PLC                             |
|                               | • HMI  | • Intelligent Elevator Control System | • Traction Drive           |                                   |
| <b>Electric Power:</b>        | • SVG  | • Solar Inverter                      | • UPS                      | • Online Energy Management System |
|                               | • New Energy Vehicle Electric Control System |                                       |                            |                                   |

INVT Copyright.  
Information may be subject to change without notice during product improving.

Y8/01-04(V1.1)