

All **MEZ** motors are dynamically balanced with **half key** as standard and the vibration severity corresponds with **vibration severity level A** (grade N -normal), unless option 'L00-Execution with **vibration severity level B**' (reduced vibration severity) is selected.

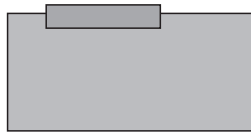

Balancing with **Full key**

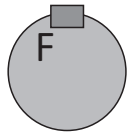
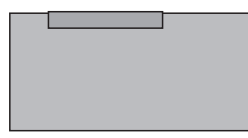
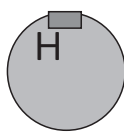

Balancing with **Half key**

For **Half key** balancing the following symbol is marked on the rating plate



As per IEC 60034-14 these are the **vibration limit values** for rotor balancing:

Vibration level	Frame size	56 < frame < 132			132 < frame < 280			frame > 280		
		Displacement	Velocity	Acceleration	Displacement	Velocity	Acceleration	Displacement	Velocity	Acceleration
	Mounting	μm	mm/s	m/s^2	μm	mm/s	m/s^2	μm	mm/s	m/s^2
A	Free suspension	25	1.6	2.5	35	2.2	3.5	45	2.8	4.4
	Rigid mounting	21	1.3	2.0	29	1.8	2.8	37	2.3	3.6
B	Free suspension	11	0.7	1.1	18	1.1	1.7	29	1.8	2.8
	Rigid mounting	-	-	-	14	0.9	1.4	24	1.5	2.4

The interface frequencies for displacement/velocity and velocity/acceleration are 10Hz and 250Hz respectively.

When evaluating the general vibration of the **Installed Electric Motors** the **RMS vibration velocity** is generally tested [mm/s] (frequency bandwidth between 10Hz and 1000Hz).

This technique is generally sufficient. The limit values for the vibration severity values are defined by ISO 10816-1 depending on motor classes.

The vibration condition is classified as follows:

- A - recently commissioned motor installation
- B - unlimited satisfactory long time operation
- C - short-time operation
- D - vibration level that causes damage to the motor

RMS vibration velocity	Class I	Class II	Class III	Class IV
0.28 mm/s				
0.45 mm/s	A			
0.71 mm/s		A	A	A
1.12 mm/s	B			
1.8 mm/s		B		
2.8 mm/s			B	
4.5 mm/s	C	C	B	B
7.1 mm/s			C	B
11.2 mm/s	D	D	C	C
18 mm/s			D	C
28 mm/s	D	D	D	D
45 mm/s			D	D

Vibration testing points

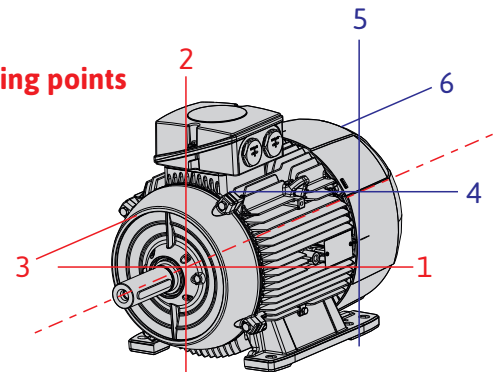

Class I	Industrial electrical motors up to 15kW
Class II	Industrial electrical motors 18.5kW to 75kW with no special foundations or rigid mounted motors up to 300kW on special foundations
Class III	Large prime-movers and other large motors with rotating masses mounted on rigid stiff foundations
Class IV	Large prime-movers and other large machines with rotating masses mounted on soft foundations (turbo generator sets, gas turbines with P>10 MW)

If the vibration of the installed motor is classified as **C** or **D** the installation /connection to the driven equipment has to be fixed.