



Operation and Installation Instructions for 4COA Electric Pumps.

Application

Electric Pumps of COA series have been designed for pumping cutting and coolant liquids and compounds with maximum viscosity of $150\text{m}^2\cdot\text{s}^{-1}$ (at 20°C). The rating plate's data is for viscosity of $1\text{m}^2\cdot\text{s}^{-1}$ (at 20°C). The pumped volume decreases with the increased viscosity of the pumped liquid.

Operation Conditions

Suitability of the use of the COA pumps for a given working environment is determined by the degree of protection of the pump. The pumps can be continuously used at a reduced flow at max altitude of 2000 metres and max pumped liquid temperature of $+60^\circ\text{C}$.

Fitting the Pumps to Machine Tool Tank

1. The pumps are designed to operate in vertical position and using the flange they are mounted on top of the coolant tank. The pumps must be visually checked and the free rotation of the shaft verified before installation.
2. The electrical installation of the pumps must be carried out by a qualified electrician and all local standards and recommendations must be observed.
3. The direction of rotation is clearly marked on the propeller chamber by an arrow and must be maintained at all times.
The direction of rotation could be checked by viewing the shaft through an opening in the upper part of the propeller chamber of the types COA 2,4,6.
The direction of rotation could be checked by viewing the shaft through an opening in the electric motor's endshield of the types COA 10,14,16,25.
4. The inlet suction opening must be positioned in such a way so the suction of sediment and impurities is prevented. The re-cycled coolant liquid must be filtered in order to prevent large impurities entering the pump. The max coolant level in the tank is 20 mm under the pump flange. There must be the minimum coolant level maintained in the tank so the pump's propeller chamber is immersed in the coolant liquid at all times.
5. If any maintenance and/or repairs are to be carried out on the pump the electric inlet cable must be isolated before dismantling the pump from the tank.
6. The cable entry can be rotated at 90° by turning the terminal box.

Disassembling of the Pump

1. Dismantle the screws holding the propeller chamber cover.
2. Pull the propeller using a suitable puller.
3. Shift the rubber ring on the shaft away from the pump's flange.
4. Using a hotplate or induction heater heat the stator frame slightly. Using a nylon block tap on the terminal box lug to loosen the electric motor frame from the stem assembly. Do not heat the frame of types COA 10,14,16,25 but just remove the nuts and the studs to disassemble the pump.
5. Remove the rubber ring from the shaft.
6. Remove the rotor from the stator. In case it is difficult to remove the bearing from its housing leave the frame to cool down and then heat it up again.
7. Use suitable puller to remove the bearings.
8. Removal of the stator pack from the frame is to be carried out by an authorised repairer only.

Assembling the Pump

1. Fit the bearings on the pump shaft.
2. Put the rotor into the stator and re-fit the rubber ring on the shaft.
3. The contacting surface between the electric motor frame and stem assembly must be degreased and a metal bonding agent applied.
4. Press the electric motor frame and stem assembly together. Ensure free rotation of the shaft in both directions.
5. Press the propeller on the shaft end so the gap between the propeller and the contacting surface of the propeller chamber is 1 mm.
6. Fit the propeller chamber cover and fix it with its two screws.
7. Make sure that the propeller does not touch the propeller chamber cover and that free rotation of the propeller in its chamber is enabled.

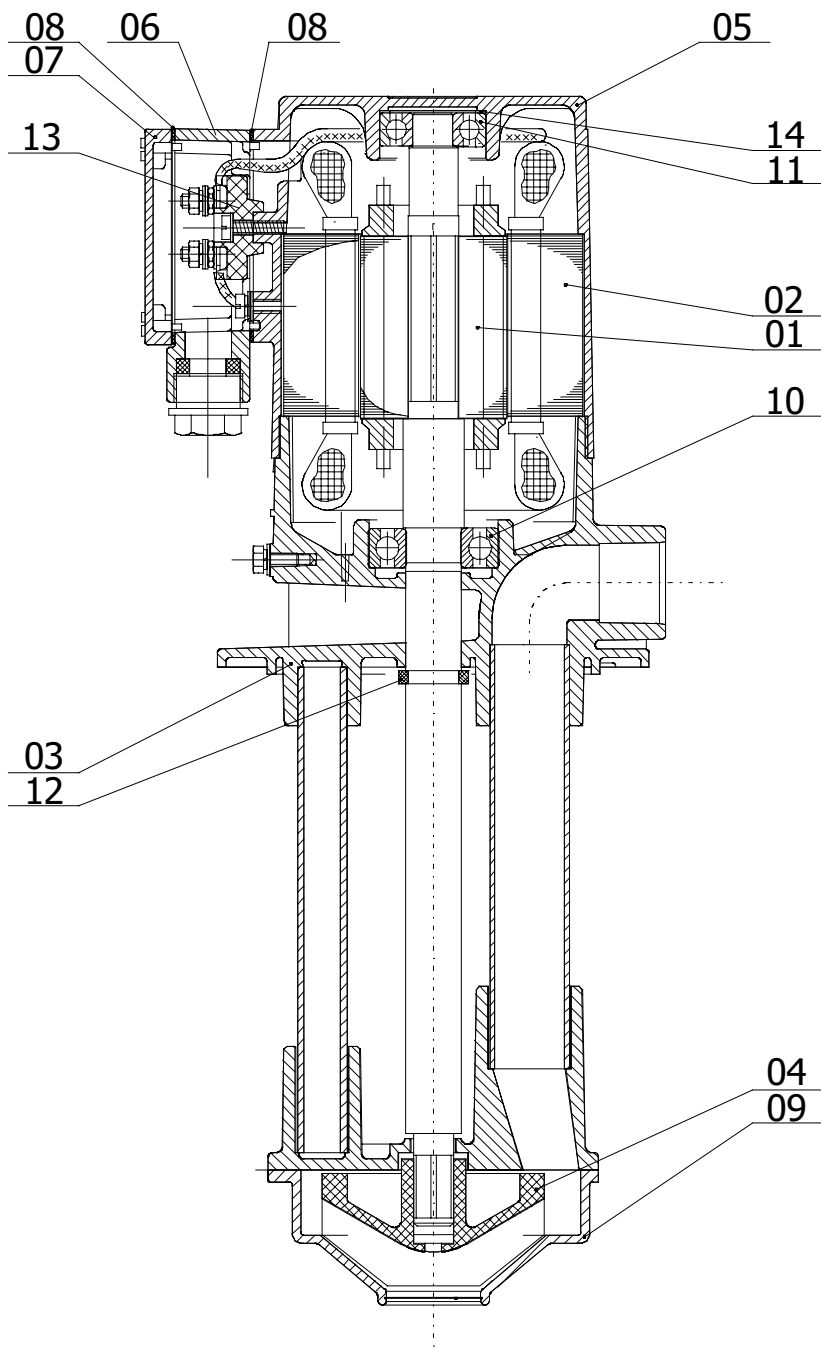

- 01 Rotor with Shaft
- 02 Wound Stator Pack
- 03 Chamber
- 04 Propeller
- 05 Electric Motor Frame
- 06 Terminal Box
- 07 Terminal Box Lid
- 08 Seal
- 09 Propeller Chamber Lid
- 10 Bottom Bearing
- 11 Top Bearing
- 12 Rubber Ring
- 13 Terminal Board
- 14 Wavy Washer

Spare Parts' References

Pos	Spare Part	Pump Type						
		COA1	COA2	COA4	COA6	COA10,14	COA16	COA25
10	Bottom Bearing	6203 Z	6203 Z	6203 Z	6203 Z	6204 Z	6204 Z	6204 Z
11	Top Bearing	6201 Z	6201 Z	6201 Z	6201 Z	6201 Z	6202 Z	6304 Z