

ELECTRIC MOTOR ENQUIRY SHEET

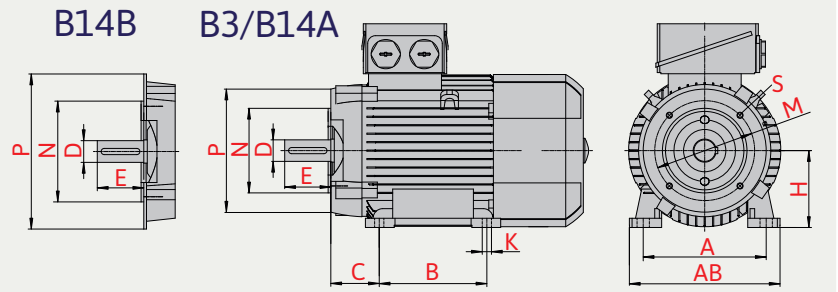
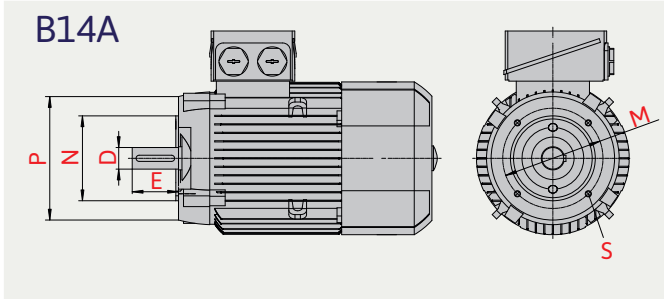
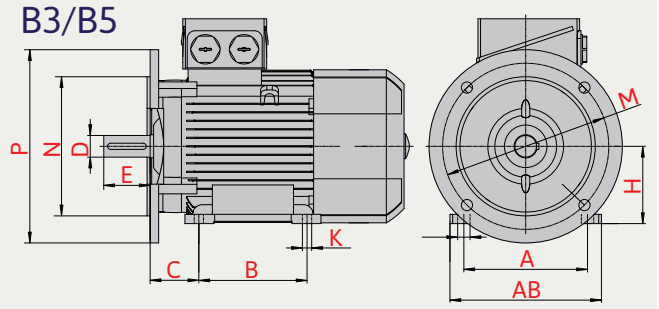
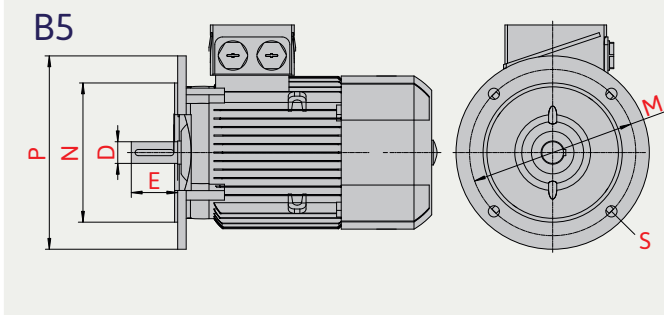
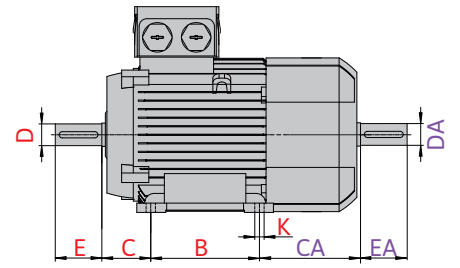
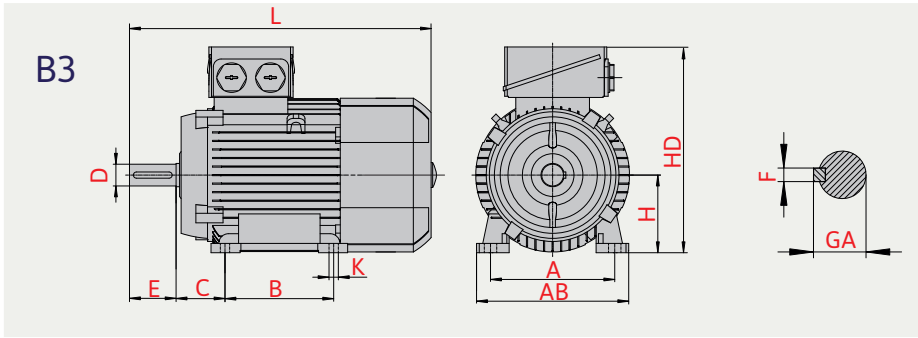

MAKE	TYPE	kW	Amps	Volts	Hz	rpm	IP rating

POLES: 2pole 4pole 6pole 8pole Specify

56	63	71	80	90S	90L	100L	112M	132S	132M	160M	160L	180M

180L	200L	225S	225M	250M	280S	280M	315S	315M	315L	355S	355M	355L

MOUNTING: B3 B5 B3/B5 B14A B3/B14A B14B B3/B14B

EFFICIENCY CLASS: IE1 IE2 IE3 IE4 Below IE1 N/A

FRAME MATERIAL: Aluminium Cast Iron

FEET				FLANGE				General			SHAFT		
A	B	AB	C	P	N	M	S	L	H	HD	D	E	F
											DA	EA	CA

TERMINAL BOX: Top Left Right (When looking at the shaft)